

## AT831R MINIATURE CARDIOID REMOTE-POWERED CONDENSER MICROPHONE

### Description

The AT831R is a miniature condenser microphone with a cardioid polar pattern. It has been designed for hands-free applications in sound reinforcement systems and for use by professional musicians, especially for pickup of acoustic guitar. The AT831R provides improved gain before feedback that normally cannot be achieved with miniature omnidirectional microphones. Close-up voice and instrument pickup are crisp and clean, yet full sounding, while suppression of background noise is significantly improved over that of stand-mounted full-size cardioid microphones.

Audio-Technica design engineers have utilized the newest low-mass technology in the quest for superior performance. The permanent charge is now on the fixed back plate, rather than the moving element. With A-T fixed charge "back plate" construction, a gold-vaporized diaphragm just 2 microns thick (or about 0.000079") can be used. This reduces moving mass, thus improving frequency response and transient response while reducing distortion.

The AT831R is intended for use in professional applications where remote power is available. It will accommodate any external phantom power source supplying from 9V to 52V DC, such as the AC-powered Audio-Technica AT8801 single-channel and CP8506 four-channel 48V phantom power supplies.

The microphone element is enclosed in a rugged housing with low-reflectance finish. Internal construction is designed to minimize handling and clothing noise. A 25' (7.6 m) cable is provided between the microphone and remote power module. An AT8417 clothing clip, AT8444 guitar adapter and AT8418 UniMount® instrument mount are provided, as well as an accessory AT8116 windscreen. The microphone is well protected by a specially-designed carrying case.

### Operation and Maintenance

The microphone may be worn on the person or attached to a musical instrument. If used with an instrument, it may be attached by means of the provided guitar adapter or UniMount® microphone instrument mount. The microphone can be attached to clothing using the clip provided. An open-pore foam windscreen simply slips over the head of the microphone, effectively reducing wind noise or "popping" when used extra close.

Output is low impedance balanced. The XLRM-type output connector mates with XLRF-type cable connectors. The balanced signal appears across Pins 2 and 3 while the ground (shield) connection is Pin 1. Output is phased so that positive acoustic pressure produces positive voltage at Pin 2 in accordance with industry convention.

While a modern condenser microphone is not unduly sensitive to the environment, temperature extremes can be harmful. Exposure to high temperatures can result in gradual and permanent reduction of the output level. Avoid leaving the microphone in the open sun or in areas where temperatures exceed 110° F (43° C) for long periods of time. Extremely high humidity should also be avoided.

### Architects and Engineers Specifications

The microphone shall be a fixed-charge condenser with a cardioid polar pattern and a frequency response of 40 Hz to 20,000 Hz. It shall be capable of operating from an external 9V to 52V DC phantom power source. Nominal open-circuit output voltage shall be 7.9 mV at 1 kHz, 1 Pascal. Output with the included power module shall be low impedance balanced (200 ohms).

The microphone shall have a 25' (7.6 m) miniature cable between the microphone and remote power module. The remote power module shall terminate in a 3-pin XLRM-type connector.

The microphone shall be mountable in an included guitar adapter, instrument mount or clothing clip. The microphone shall be 0.98" (24.8 mm) long with a diameter of 0.40" (10.2 mm). The microphone weight shall be 0.1 oz (2.8 grams). Finish shall be low-reflectance matte.

The Audio-Technica AT831R is specified.

### Frequency Response

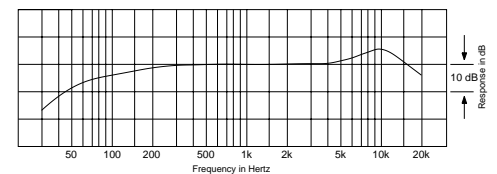

LEGEND ——— 12" or more on axis

# AT831R

## Polar Pattern

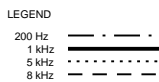
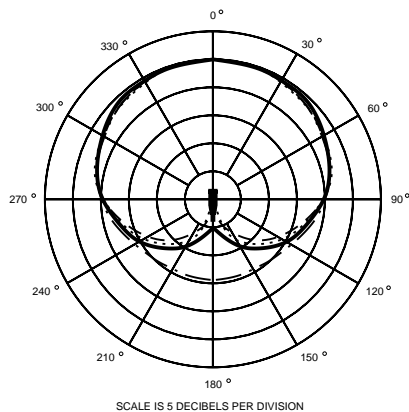

## AT8418 UniMount® Microphone Instrument Mount



## AT831R SPECIFICATIONS†

<b>ELEMENT</b>	Fixed-charge back plate permanently polarized condenser
<b>POLAR PATTERN</b>	Cardioid (Unidirectional)
<b>FREQUENCY RESPONSE</b>	40-20,000 Hz
<b>OPEN CIRCUIT SENSITIVITY</b>	-42 dB (7.9 mV) re 1V at 1 Pa*
<b>IMPEDANCE</b>	200 ohms
<b>MAXIMUM INPUT SOUND LEVEL</b>	141 dB SPL, 1 kHz at 1% T.H.D.
<b>DYNAMIC RANGE (TYPICAL)</b>	112 dB, 1 kHz at Max SPL
<b>SIGNAL-TO-NOISE RATIO†</b>	65 dB, 1 kHz at 1 Pa*
<b>PHANTOM POWER REQUIREMENTS</b>	9-52V DC, 2 mA typical
<b>WEIGHT (LESS CABLE AND ACCESSORIES)</b>	
<b>MICROPHONE</b>	0.1 oz (2.8 grams)
<b>POWER MODULE</b>	1.8 oz (51.4 grams)
<b>DIMENSIONS</b>	
<b>MICROPHONE</b>	0.98" (24.8 mm) long, 0.40" (10.2 mm) diameter
<b>POWER MODULE</b>	3.13" (79.5 mm) long, 0.83" (21.0 mm) diameter
<b>OUTPUT CONNECTOR (POWER MODULE)</b>	Integral 3-pin XLRM-type
<b>CABLE</b>	25' (7.6 m) long (permanently attached to microphone), 0.13" (3.2 mm) diameter, 2-conductor, shielded cable with TA3F output connector
<b>ACCESSORIES FURNISHED</b>	AT8417 clothing clip; AT8418 UniMount® microphone instrument mount; AT8444 guitar adapter; AT8533 remote power module; AT8116 windscreen; protective carrying case

† In the interest of standards development, A.T.U.S. offers full details on its test methods to other industry professionals on request.

\* 1 Pascal = 10 dynes/cm<sup>2</sup> = 10 microbars = 94 dB SPL

† Typical, A-weighted, using Audio Precision System One.

## XLRM-Type Plug Wiring Low Impedance Balanced

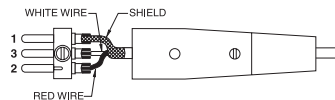

## Dimensions

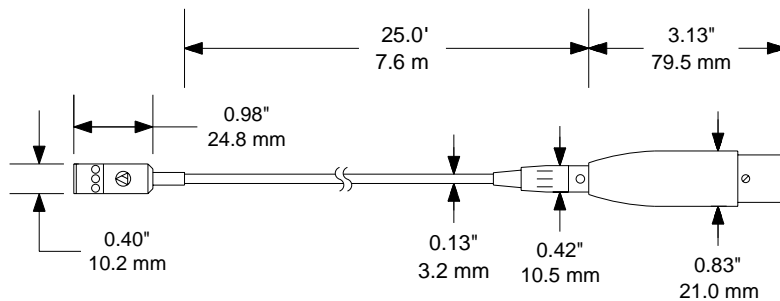

## Optional Accessories:

- CP8201 line matching transformer (Lo-Z to 50,000 ohms).
- AT8202 adjustable in-line attenuator for use with balanced Lo-Z microphones.
- AT8314 2-conductor, shielded, vinyl-jacketed, broadcast-type cable with XLRM-type connector at microphone end, XLRM-type connector at equipment end. Available in 10', 20', 25', 30', 50' & 100' lengths.
- AT8412 double clothing clip.
- AT8414 tie tac.
- AT8438 stand adapter.
- CP8506 four-channel 48V phantom power supply (AC powered).
- AT8801 single-channel 48V phantom power supply (AC powered).

## One-Year Limited Warranty

Audio-Technica microphones and accessories purchased in the U.S.A. are warranted for one year from date of purchase by Audio-Technica U.S., Inc. (A.T.U.S.) to be free of defects in materials and workmanship. In event of such defect, product will be repaired promptly without charge or, at our option, replaced with a new product of equal or superior value if delivered to A.T.U.S. or an Authorized Service Center, prepaid, together with the sales slip or other proof of purchase date. **Prior approval from A.T.U.S. is required for return.** This warranty excludes defects due to normal wear, abuse, shipping damage, or failure to use product in accordance with instructions. This warranty is void in the event of unauthorized repair or modification.

**For return approval and shipping information,** contact the Service Department, Audio-Technica U.S., Inc., 1221 Commerce Drive, Stow, Ohio 44224.

Except to the extent precluded by applicable state law, **A.T.U.S. will have no liability for any consequential, incidental, or special damages; any warranty of merchantability or fitness for particular purpose expires when this warranty expires.**

This warranty gives you specific legal rights, and you may have other rights which vary from state to state.



Audio-Technica U.S., Inc., 1221 Commerce Drive, Stow, Ohio 44224

Audio-Technica Limited, Old Lane, Leeds LS11 8AG England

Form No. 0310-0840-02-B/W © 1998 Audio-Technica U.S., Inc. Printed in U.S.A.

Outside the U.S.A., please contact your local dealer for warranty details.