



U-81 OCTAVO

*Eight Discrete UHF Channels
Wireless Microphone System*



OWNER'S MANUAL

TABLE OF CONTENTS

TABLE OF CONTENTS	2
INTRODUCTION	2
USING THIS MANUAL	2
SYSTEM FEATURES.....	3
U-81 OCTAVO RECEIVER OPERATION INSTRUCTIONS	4
UH-81 HANDHELD TRANSMITTER	6
UB-81 BODYPACK TRANSMITTER	7
CAUTIONS AND TROUBLESHOOTING	10
TIPS.....	11
SPECIFICATIONS.....	12
FREQUENCY PLAN	13
SERVICE INFORMATION.....	14
WARRANTY	15

INTRODUCTION

Thank you for choosing the Nady U-81 OCTAVO wireless system, we know you will be very pleased with its performance and features. The Nady U-81 OCTAVO is a professional 8-channel UHF wireless system which offers the clearest, most natural sound available in wireless today. The Nady U-81 OCTAVO delivers eight discrete channels on selected frequency bands 902-928MHz and 944-952MHz for interference-free performance in any application or locale. It also features Nady's proprietary companding and low noise circuit for an industry best 120dB dynamic range.

USING THIS MANUAL

This booklet provides information regarding the use of the U-81 OCTAVO wireless systems: The U-81 OCTAVO wireless microphone receiver, the UH-81 Handheld Microphone transmitter and the UB-81 bodypack microphone transmitter. It includes a description of features and a step-by-step guide to operation of the unit. This manual should answer any questions you may have about the operation and servicing of your U-81 OCTAVO wireless system.

SYSTEM FEATURES

U-81 OCTAVO Wireless Receiver

- Operates on select UHF frequencies on 902-928MHz and 944-952 MHz bands
- Eight independent single-channel UHF wireless receivers in a single housing for simultaneous operation for up to eight transmitters
- Front panel LED display indicates the RF and AF status for each channel
- Ch 1-8 individual balanced fixed XLR MIC level outputs and adjustable Unbalanced LINE level SUM 1/4" jack output for 8-in-1 MIX audio output with separate volume control for each channel
- Nady's exclusive patented companding circuitry with 120dB dynamic range and highest quality audio for an unsurpassed UHF performance
- Dual removable high gain antennas with TNC connector, front or back mounting
- Standard 19" 1U, all-metal rack mount housing
- Externally powered with AC/DC adapter included
- Choice of any combination of 2 transmitters: UH-81 and/or UB-81

UH-81 Handheld Microphone Transmitter

- Nady DM-50D neodymium cartridge delivers transparent vocals, maximum feedback rejection and minimal handling noise
- ON/STDBY/OFF switch allows convenient audio muting while transmitter "ON"
- Status LED indicator flashes once for unit "ON"; lights steady for low battery alert
- 2 X AA alkaline or NiMH battery operation
- Rugged ABS and rubber-coated housing with integral antenna

UB-81 Bodypack Transmitter

- Choice of headworn or lavalier microphone operation with convenient input volume control for proper level adjust
- OFF/STDBY/ON switch allows convenient audio muting while transmitter "ON"
- Status LED indicator flashes once for unit "ON"; lights steady for low battery alert
- Single 9V alkaline or NiMH battery
- Lightweight, rugged ABS housing with integral antenna

U-81 OCTAVO RECEIVER OPERATING INSTRUCTIONS

1. Rack-Mounting The Receiver

The U-81 OCTAVO receiver has pre-drilled holes for rackmounting. Simply attach the **Rack Mount Ears (1)** on each side and fasten with supplied screws.

(Note: Do not mount the receiver in a rack directly above an amplifier or other source of high heat. This could degrade the performance of the U-81 OCTAVO. Always ensure adequate airflow and heat dissipation in any rack configuration.)

2. Installing Antennas

If not rackmounting the receiver, the two **Antennas (2a)** can be mounted directly on the **Receiver Antenna Input Jacks (2b)** on the receiver's back panel. If rackmounting, antennas can be front mounted on the **Rack Ear Jacks (2d)**, after installing the jacks on the **Rack Ears (1)** provided. Use the **Antenna Connecting Cables (2c)** to feed the received signal to the receiver's antenna jacks as pictured, connecting them from the backs of the rack ear jacks to the receiver antenna jacks. The optimal positions of the antennas are 45° from the receiver, so 90° from each other.

3. Powering The Receiver

Powering the receiver by plugging the provided 15VDC/1000mA adaptor into the **DC INPUT jack (3)** on the back of the receiver; then plug the adapter into an AC outlet. *(Note: Any 15VDC source with 1200mA capacity can also be used.)* Turn volume controls of all channels counterclockwise for minimum setting. Once the receiver is connected to a power source, press the power switch to the ON position, **Power LED indicator (4)** is ON. The **TX LEDs indicator (7)** and **AF LEDs indicator (8)** on the front panel of the receivers will not light up at this time, but only until one or more of the eight channels is receiving a signal from your system's transmitters. To turn OFF, press the **Power Switch (5)** to the OFF position.

4. Mute (Squelch) & RF LED Display

The U-81 OCTAVO has a preset mute (Squelch) internally for each channel for maximum range and performance. There is no need to adjust this. In normal condition, the **RF LEDs indicator (7)** should be lit when a correct frequency is received from a transmitter. However, when the **RF LEDs indicator (7)** is extinguished, the transmitter is out of range for that given location, and the user should move closer to the receiver to re-establish the radio link.

5. AF LED Display

The U-81 OCTAVO receiver is equipped with an **AF LEDs indicator (8)**. The AF LED indicator lights whenever an audio signal is being received from a modulated transmitter signal. The AF LED indicator is not a peak level indicator so it can light continuously during audio signal input to the transmitter.

6. Connecting Audio Outputs

(Using the UH-81 handheld or UB-81 bodypack transmitters)

- For microphone use, the fixed **Balanced XLR out (9)** or the adjustable **1/4" MIX out (10)** can be used. The U-81 OCTAVO audio output stage of each channel is configured for XLR balanced microphone level when loaded by a 600 ohm balanced or unbalanced mixer input. Make sure the Phantom Power on your mixing board is turned off and the volume is turned down when making the audio connections. Start the receiver VOLUME at minimum and adjust until the level is optimal.

U-81 OCTAVO RECEIVER OPERATING INSTRUCTIONS

- For each channel you wish to use, insert an audio cord with a XLR female plug into its **Balanced XLR out (9)** jack on the back of the receiver. Plug the other end of this cord into your amplifier, effects or mixing board. The individual receiver outputs are all fixed mic level.
- The U-81 OCTAVO also has a **MIX unbalanced output (10)**, which is a SUM line level output of all the channels. To use it, just plug an audio cable with a 1/4" mono plug into the **MIX out (10)** and plug the other end to your amplifier or mixing board. The front panel individual **receiver volume controls (6)** can be used to adjust any channels level on the **MIX out (10)**. Turn the volume controls on each of the channels being used clockwise to near full gain. Adjust each volume up or down so that no audio distortion is present when the amplifier or mixer is set at their usual levels. *(Note: Turn the volume controls of any unused channel all the way off, full counter-clockwise, so that only the channels being used are in the MIX output.)*
- Your U-81 OCTAVO is now operational and ready to use. Now that you have completed the above step, proceed to instructions for the UH-81 or UB-81 transmitters included with your system.

Note:

- To prevent possible undesired noise during use, keep the volume controls of unused channels (corresponding transmitter off) turned off in the amplifier or the mixer. The audio should only be "live" if the transmitter is on.
- As when making any connection, make sure the amplifier or mixing board volume is at the minimum level before plugging in the receiver to avoid possible sound system damage.
- Only one transmitter can be used with one receiver. It is not possible to use two transmitters on the same frequency and mix the output of these transmitters into one wireless receiver.

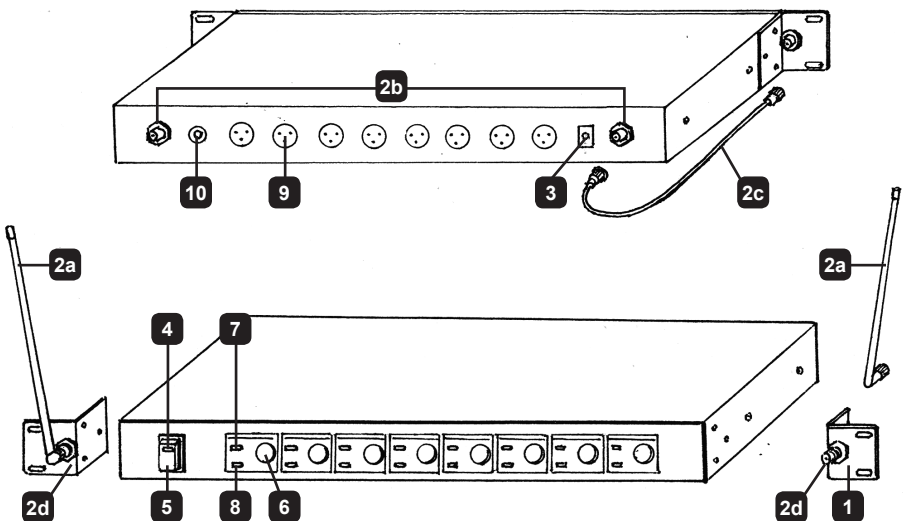

UH-81 HANDHELD MIC TRANSMITTER

7. UH-81 Transmitter Set Up

- Release the **Battery cover (11)** by pressing the locking tab and slide down as per arrow, exposing the **Battery holder (12)**. Insert two fresh AA alkaline or NiMH batteries, observing the correct polarity as marked, and slide the battery cover back on to the microphone. Make sure the cover is closed completely. Fresh alkaline batteries can last up to 10 hours in use, but in order to ensure optimum performance, it is recommended that you replace the battery after every 6-8 hours of use. NiMH batteries should be replaced with fresh ones recharged fully (with separate charger, not supplied, and as per its charging instructions) whenever low or dead battery status is indicated as per the following.
- Turn on the UH-81 by sliding the **ON/STDBY/OFF switch (13)** to the STANDBY position first (transmitter on, audio muted) or the ON position (transmitter and audio both on). The **Battery indicator LED (14)** will give a single quick flash, indicating usable battery strength. In the case of dead or low batteries, the LED will either not go on at all or will stay on continuously, indicating that the batteries should be replaced with fresh ones. To preserve battery life, turn the transmitter off when not in use.
- The microphone is now ready to use. The **RF Signal LED (7)** on the corresponding channel of the U-81 OCTAVO receiver should now be lit, indicating a received signal from the same frequency transmitter. When ready to speak, slide the **ON/STDBY/OFF switch (13)** to the ON position.
- Adjust the volume of the receiver as per the Connecting Audio Outputs, section 6 of the U-81 OCTAVO receiver instructions above.

[Note: Observe care in selecting P.A. volume, transmitter location and speaker placement so that acoustic feedback (howling and screeching) will be avoided. Please also note the pickup pattern characteristics of the microphone selected. Omni-directional mics pick up sound equally from all directions, and are prone to feedback if not used carefully. Unidirectional mics, as provided with the UH-81, are more resistant to feedback, but pick up sound sources best that are directly in front of the mic. Also, mics that are farther from the sound source, such as lavaliers, require more acoustic gain and thus are also more prone to feedback than close-source mics such as handheld or headworn models that are used close to the mouth].

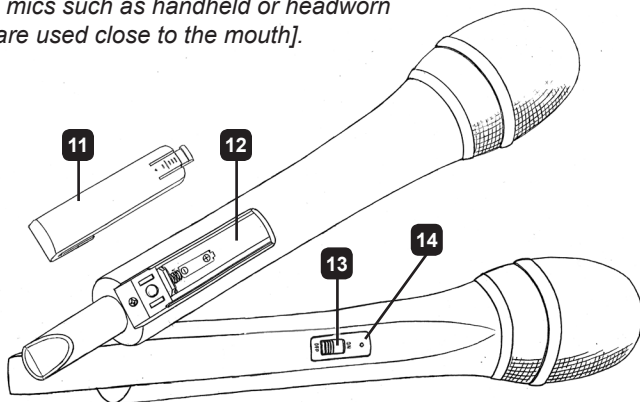

UB-81 BODYPACK MIC TRANSMITTER

8. UB-81 Transmitter Set Up

- Install by battery for the UB-81 transmitter by snap-opening the **Battery door (15)** and inserting a fresh 9V alkaline or NiMH battery into the **Battery compartment (16)**, observing the correct polarity. Close the battery door to its original position and completely cover the battery. Fresh alkaline batteries can last up to 10 hours in use, but in order to ensure optimum performance, it is recommended that the battery be replaced after 6-8 hours of use. A NiMH battery should be replaced with another recharged fully (with separate charger, not supplied, and as per its charging instructions) whenever low or dead battery status is indicated as per the following.
- Selecting Audio Input Operating Mode of the UB-81. The UB-81 is equipped with two **Input selector switches (17)** located under the cover on the circuit board for selecting the type of audio input you will be supplying to the transmitter. Select from the choice of two positions: HEADWORN MIC and LAVALIER MIC (Condenser Microphones).
- There are two switches with selectable positions HM, LT together at same time.
To select inputs: (see chart on page 9)
 - A. Headworn Mic — set both switches to “HM”
 - B. Lavalier Mic — set both switches to “LT”

*(Note: Use only the input audio source as per the input selected with the internal **Audio input selector switches (17)** or the audio will not be optimal—a muddy or distorted sound may result. Do not select the GT setting as the U-81 receiver outputs are not suitable for wireless instrument use.)*

- Connection for the selected input to the UB-81 is provided with a **3.5 mm Locking jack (18)** for connecting the audio input selected. Connect either the **Instrument cord (19)** or the **Headworn mic (20)** or **Lavalier mic cord (21)** as desired, according to the input selected. To secure the connection, turn the slip ring on the plug clockwise to thread it on the jack. To unplug, reverse the process. Slip the transmitter into a pocket or **Clip (22)** it on to your clothes or instrument strap (if using the UB-81 as an instrument transmitter).
- Turn on the UB-81 by sliding the **ON/STDBY/OFF switch (23)** to the STANDBY position (transmitter on, audio muted) or the ON position (transmitter and audio both on). The **Battery indicator LED (24)** will give a single quick flash, indicating usable battery strength. In the case of a dead or low battery, the LED either will not go on at all or will stay on continuously, indicating that the battery should be replaced with a fresh one. To conserve battery life, turn unit off when not in use.
- The U-81 transmitter is now ready to use. The **RF Signal LED (7)** on the corresponding channel of the U-81 OCTAVO receiver should now be lit, indicating a received signal from the same frequency transmitter.

UB-81 BODYPACK MIC TRANSMITTER

- Adjust the volume of the receiver as per the Connecting Audio Outputs, section 6 of the U-81 OCTAVO receiver instructions above. *[Note: Observe care in selecting P.A. volume, transmitter location and speaker placement so that acoustic feedback (howling and screeching) will be avoided. Please also note the pickup pattern characteristics of the microphone selected. Omni directional mics pick up sound equally from all directions, and are prone to feedback if not used carefully. Unidirectional mics are more resistant to feedback, but pick up sound sources best that are directly in front of the mic. Also, mics that are farther from the sound source, such as lavaliers, require more acoustic gain and thus are also more prone to feedback than close-source mics such as handheld or headworn models that are used close to the mouth].*

9. Microphone Use (with either a lavalier or headworn mic)

- Secure the connection from the **Lavalier (21)** or **Headworn mic cord (20)** by turning the slip ring on the plug into the transmitter clockwise to thread it on to the jack. To unplug, reverse the process. To use the lavalier mic, attach it at chest level. Do not place it too close to the mouth—a distance of about six inches usually works best. To use the headworn mic, place it on the head and adjust the boom so that the mic is about one inch to the side of the front of the mouth. When ready to speak, slide the **ON/STDBY/OFF switch (23)** to either the “STDBY or ON” position.
- For optimum performance, an **Input level control (25)** is provided. Adjust the gain by turning the control with a small screwdriver. For lavalier mic use, it is recommended that the level be set at about 1/2 maximum. For headworn mic use, it may be advisable to turn the gain down somewhat, depending on the volume levels expected. In either application, experiment and set for maximum possible gain without audible distortion on the high level peaks.

(Note: Turning down the gain too much can compromise the signal-to-noise and it is not recommended.)

UB-81 BODYPACK MIC TRANSMITTER

INPUT SELECTOR SWITCHES

	GT	HM	LT
Headworn	<input type="checkbox"/>	<input checked="" type="checkbox"/>	<input type="checkbox"/>
Lavalier	<input type="checkbox"/>	<input checked="" type="checkbox"/>	<input type="checkbox"/>

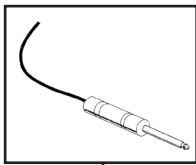
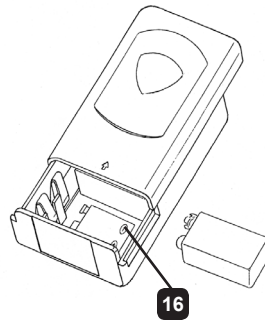
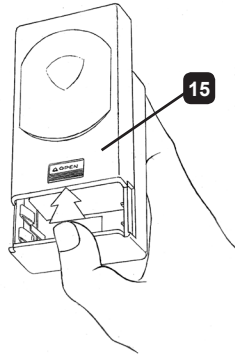
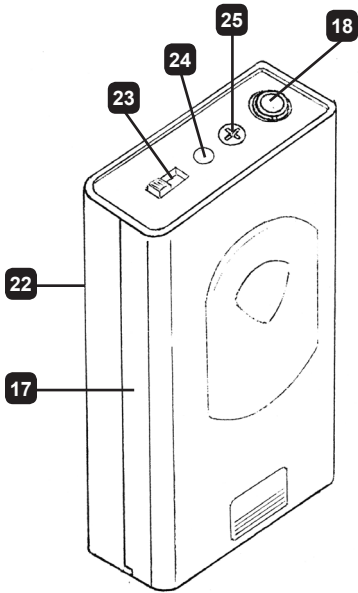

19

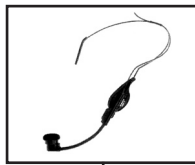

20

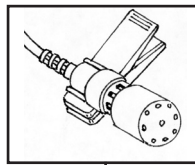

21

CAUTIONS AND TROUBLESHOOTING

10. No Audio

If you are not getting audio through the U-81 OCTAVO system, slide the transmitter POWER or MUTE (STDBY) switch to ON, carefully check all connection and system setup. Check or replace transmitter battery. Check that the receiver is powered. The receiver and transmitter must be set to operate on the same RF channel.

11. Audio Distorted or Unwanted Sound

Remove or turn off nearby RF sources (such as other wireless system, CB radio, CD player, computer, digital effect, ect...) Check or replace transmitter battery.

12. Feedback

Observe care in selecting P.A. volume, transmitter location and speaker placement so that the acoustic feedback (howling and screeching) will be avoided. Please also note the pickup pattern characteristics of the microphone selected. Omnidirectional mics pick up sound equally from all direction, and are prone to feedback if not used carefully. Unidirectional mics are more resistant to feedback. However, pick up sound source best that are directly in front of the mic. In addition, mics that are farther from the sound source, such as lavalier, required more acoustic gain and thus are also more prone to feed back than close-source mics such as handheld or headworn models that are used close to the mouth.

13. RF Interference

If you encounter receiving interference (from other than an operating TV station), often it can be checked by turning off each transmitter at a time to find the source of causing interferences. Please note that wireless frequencies are shared with other radio services. According to FCC regulations, wireless microphone operations are unprotected from interference from other licensed operations in the band. If any interference is received by any Government or non-government operation, the wireless microphone must be cease operation or change frequencies. The above statement is valid only for use in the U.S.A.

14. Signal Loss

Reposition the receiver and perform walk-thought test. If audio dropouts persist, locate "dead" spots and avoid them during performance. Check receiver MUTE level setting. Check or replace transmitter battery.

TIPS

- If the Volume Control of the receiver is set too high, it may overdrive the input of the mixer, causing distortion. Conversely, if the output is set too low, the overall signal-to-noise ratio of the system may be reduced. Adjust the output level of the receiver such that the highest sound pressure level going into the microphone causes no input overload in the mixer, and yet permit the mixer level control to operate in the normal range (not too high and not too low). This provides the optimum signal-to-noise for the entire system.
- Do not place the receiver antennas within 3 feet (1 meter) of another receiver or antennas.
- The receiver antennas should be kept away from any metal surface.
- For the best operation, the receiver should be placed at least 3 feet above the ground and 3 feet away from a wall or metal surfaces. All operating transmitters should be also at least 3 feet from the U-81 OCTAVO receiver. Keep antennas away from noise source such as motors, automobiles, neon light, signal processor, computer, as well as large metal objects.
- A single receiver cannot receive signal from two or more transmitters on the same frequency simultaneously.
- For operation with an external antenna, low loss RF shielded cable should be used and the length of the cable should not exceed 10 feet (3 meters).
- Position the receiver such that it has the least possible obstructions between it and the transmitter. Line of sight is best!
- The transmitter and the receiver should be as close as possible but never less than 1 meter.
- Before inserting the batteries, please make sure that they are inserted according to the correct polarity.
- Use only brand new alkaline batteries. Do not use “general purpose” batteries. When batteries are weak, replace the batteries altogether at the same time. Do not mix and use new and old batteries together.
- Turn the transmitter off when it is not in use. Remove the batteries if it is not to be used for a long period.
- Headset and lavalier mic users, note that the microphone element can easily be destroyed by the buildup of salts and minerals from perspiration and saliva. It is good practice to put a windscreen on the mic at all times to protect it.

SPECIFICATIONS

OVERALL SYSTEM PERFORMANCE

RF Carrier Frequencies	Selected factory installed frequencies between 902-928MHz and 944-952MHz
Frequency stability	+/-0.005% (Crystal Controlled)
Audio Deviation	FM +/-20kHz normal, +/-50kHz maximum
Frequency Response	20Hz-20kHz, -3dB
Dynamic Range	120dB
Harmonic Distortion	0.5% THD, normal
Operating Range	250 feet normal, 500+feet max line of sight

RECEIVER

Reception	Mono antenna reception
Antennas	10" (25.4 cm) Dual adjustable angle
Mute Threshold	-95dBm (none-adjustable)
Image Rejection	-70dB, minimum
Balanced output	Audio outputs: +/-24mV fixed level (600 Ohms)
Unbalanced MIX output	Audio output: 360mV variable level (Open load)
Connectors	Balanced: XLR, Unbalanced: 1/4" TS, Antennas: TNC connector. DC in: 2.1mm barrel type
Indicators	Power On, RF and AF LEDs
Controls	Power ON/OFF buttons, Volume Controls
Power Requirement	15VDC/1200mA
Dimensions	14.25" x 12" x 1.75 [W / D / H] (36.20 cm x 30.50 cm x 4.45 cm) [W / D / H]
Weight	7.20 lbs (3.37 Kg)

TRANSMITTERS

Models Available	UH-81 Handheld and UB-81 Bodypack
Input Connectors	
UH-81 Handheld	Integral Nady DM-50D neodymium dynamic cartridge
UB-81 Bodypack	3.5mm locking mini-jack,
Controls	
UH-81	Power ON/STDBY/OFF
UB-81	ON/STDBY/OFF, Input Level Control (LT/HM), selectable inputs—internal HM/LT switches
RF Power	20mW normal (50mW Maximum allowed by FCC)
Harmonics and Spurs	< -50 dB
Antennas	UH-81/UB-81: Internal antennas
LED Indicators	
UH-81/UB-81	Single LED flashes once for "ON", lights steady for "LOW BAT"
Battery	
UH-81	2xAA Alkaline or NiMH batteries
UB-81	Single 9V Alkaline or NiMH battery
Battery Life	8-10 Hours (Alkaline)
Dimensions	
UH-81	10.5"x 1.875" (26.7 cm x 4.8 cm)
UB-81	4.25" x 2.5"x 1.0" (10.8 cm x 6.4 cm x 2.5 cm)
Weight	
UH-81	7.5 oz (213 g) without battery
UB-81	3.1 oz (88 g) without battery

U-81 OCTAVO FREQUENCY PLAN

902-928MHz and 944-952MHz

CH 14
906.000

CH 15
908.500

CH 16
911.700

CH 17
921.300

CH 10
944.200

CH 11
945.100

CH 12
947.300

CH 18
951.600

SERVICE INFORMATION

In the U.S. If you are experiencing operational problems with your system, please refer to the Support page at www.nady.com for assistance. Should your wireless system require service, please contact the Nady Service Department at (510) 652-2411 for a Return Authorization (R/A) Number and service quote (if out of warranty). Make sure the R/A Number is clearly marked on the outside of the package that you are returning.

If your unit is out of warranty, please enclose a cashier's check or money order (or pay by credit card) per instructions by the Nady Service Department. Ship your unit prepaid to: Nady Systems, Service Department, 6701 Shellmound Street, Emeryville, CA 94608. Include a brief description of the problem you are experiencing. For service of a unit under warranty, please follow the instructions in the following section.

Outside the U.S. For service and warranty matters please contact the Nady distributor in your country through the dealer/store from which you purchased this product.

Do not attempt to service this unit yourself as it can be dangerous and will also void the warranty.

ONE-YEAR LIMITED WARRANTY

Nady Systems, Inc. warrants to the original consumer purchaser that the above unit is free from any defects in material or workmanship for a period of one year from the date of original retail purchase. If any such defect is discovered within the warranty period, Nady Systems, Inc. will repair or replace the unit free of charge, subject to verification of the defect or malfunction upon return to Nady Systems.

To the extent permitted by law, any applicable implied warranties, including warranties of merchantability and fitness are hereby limited to one year from the date of purchase. Consequential or incidental damages resulting from a breach of any applicable express or implied warranties are hereby excluded. This warranty is in lieu of all other agreements and warranties, general or special, express or implied and no representative or person including a Nady dealer, agent, or employee is authorized to assume for us any other liability in connection with the sale or use of this Nady Systems' product.

Whereas some states do not allow limitations on how long implied warranties last, and do not allow exclusion of incidental or consequential damages, the above limitations and exclusions may not apply to you. This warranty gives you specific legal rights and you may also have other rights which may vary from state to state.

This warranty is subject to the following conditions:

- 1) This system must have been purchased from an authorized Nady dealer and all warranty service must be performed by Nady's service department. Any service not performed by Nady will automatically void this warranty.
- 2) Items not covered: physical damage resulting from improper handling of the unit in transit from the factory by the shipper (Nady Systems is not responsible for such damage and all such claims must be made against the shipping company by the consignee.); defects caused by normal wear of the product (expendable parts are typically connectors, cables, potentiometers, switches and similar components); damage or defects caused by abuse, neglect, accident, failure to connect or operate the unit in any way that does not comply with applicable technical or safety regulations, or improper repair, excessive heat or humidity, alteration or unreasonable use of the unit, causing cracks, broken cases/housings or parts; damage caused by leaking batteries; finish or appearance items; items damaged in shipment en route to Nady Systems, Inc. for repair. The warranty is null and void if any Nady serial number has been removed or defaced.

How To Obtain Service:

- 1) If factory service is required, you must contact our Service Department at (510) 652-2411 for a return authorization (R/A) number. Make sure the R/A number is clearly marked on the outside of your package. (Please note: if an R/A number is not included, our Shipping Department cannot accept your package.)
- 2) Send the unit back to Nady Systems, Inc., 6701 Shellmound Street, Emeryville, CA, 94608, freight pre-paid. You must include proof of date and place of purchase (i.e., photocopy of your bill of sale) or Nady cannot be responsible for repair or replacement. Nady Systems, Inc. will not repair, nor be held responsible, for any units returned without proper identification, return address, and RA number clearly marked on the package.
- 3) Per the above, Nady will perform all warranty service and return the unit to you at no charge. Nady Systems will inform the buyer if product sent in does not meet the terms of this warranty and will provide a quote for fixing the unit and/or shipping it back exclusively at the buyer's expense.



6701 Shellmound Street | Emeryville, CA USA 94608
T 510.652.2411 | **F** 510.652.5075 | www.nady.com