

**Acoustic
Solutions**

Alpha

AER The Acoustic People®



Manual English

Acoustic Solutions

Alpha

Operating Manual

Contents:

1. Introduction
2. Safety Precautions
3. Controls and Connections
4. Operation Summary
5. Technical Data
6. Block Diagram
7. Manufacturer's Declaration



1. Introduction

Welcome to AER!

Thank you for choosing the **Alpha** – our contribution to minimal music – a professional, powerful and compact amplifier system for acoustic instruments in superb quality with AER's typical authentic, transparent and self-asserting sound performance. One channel - two individual inputs allow parallel use of instrument and microphone even though the instrument is the main focus. Dynamic controlled 40 Watts and the 8"-twin-cone speaker system give perfect performance at all sound pressure levels.

We wish you hours of happy playing with your **Alpha!**

2. Safety Precautions

The following guidelines shall help minimize the risk of injury through fire or electric shock.

1. Carefully read these safety notes before you use the device!
2. Keep these safety notes in a safe place.
3. Pay attention to all warnings, instructions and additional texts on the unit.
4. Do not install or use your amp in close proximity to water or if you are wet yourself.
5. Use your amp in a safe place where nobody can step on cables or trip over and damage them.
6. Pay attention to an unhindered air circulation around the amp, never obstruct the air vents or grilles.
7. Always pull the mains plug before cleaning your amp. Use only a dry cloth for cleaning. Avoid the use of detergents and do not let any liquids seep into the unit.

8. Use only the right fuses with the same current rating and trigger characteristic as replacements. Never mend fuses! Pull the mains plug before replacing a fuse. Should a fuse blow again after a short while, the device needs to be checked.
9. Never install your amp close to devices with strong electromagnetic fields such as large mains transformers, revolving machines, neon illumination etc. Do not lay signal cables parallel to power current cables.
10. There are no user-servicable components inside the unit. To avoid the risk of an electric shock, the unit must not be opened. All maintenance, adjustment and repair works should be carried out by qualified staff only. Any unauthorized tampering will void the 2-year warranty.
11. In keeping with the EMV regulations screened cables with correctly fitted connectors must be used for all signal connections.
12. Always use an earthed power supply with the correct mains voltage. If you are in doubt about the power outlet's ground, have it checked by a qualified technician.
13. Cable up your amp only when it is powered off.

3. Controls and Connections

Front panel top (from left to right):



input one	XLR/6.3 mm jack plug combi socket
line/mic	Signal source selector switch. line: For instruments (pickups), only via jack plug. mic: For microphones with a jack or an XLR connector.
gain	Input level control
input two	6.3 mm mono jack socket
pad	Input sensitivity selector switch pressed = lower sensitivity
gain	Input level control
clip	This indicator lights up when overload is imminent in the respective channel.

colour	This switch activates the midrange contour filter. Boosts presence and slightly cuts midrange frequencies.
bass	Bass control
middle	Midrange control
treble	Treble control
effect	Adjusts the effects send level for the corresponding channel (the internal effect is blended).
on	This LED indicates that your amplifier is ready to use
master	Adjusts the overall volume level

Back panel (from left to right):



headphones	Output for a stereo headphone set. 6.3 mm stereo jack socket. Never use mono jack plugs, otherwise the amp could be damaged!
line out	Preamp output, located behind the master volume control. 6.3 mm stereo jack socket.
DI-out	Balanced preamp output, pre master , post EQ without effects. XLR socket.
send	Output to the input of an external effects unit. 6.3 mm mono jack socket.

return	Input for the output signals of an external effects unit. 6.3 mm mono jack socket.
footswitch	connection to a double footswitch to switch internal and external effect on and off. (Tip = internal Effect, Ring = external Effect on/off). 6.3 mm stereo jack socket.
power on	Combined power switch with fuse holder and IEC mains socket.



4. Operation Summary

• Cabling and startup

Check if your local mains voltage (e.g. 120 V in the USA, 230 V in Europe) complies with the required operating voltage for your amplifier. The proper mains voltage is printed on the rating plate on the rear panel of the unit, e.g. AC 230V (AC means alternating current).

Please take care that the **master**, **effect** and **gain** controls are set to zero (left stop) and all other controls to their center positions. The pushbuttons should be switched off (not pressed).

Then make all the necessary cable connections (mains, instrument etc.).

Now you may turn on your amplifier with the **power on** switch located on the rear. The green **power** control LED will indicate operational readiness.

• Level adjustment

Using the **gain** control, **pad** and **line/mic** switches you can adapt the amplifier to your signal sources (guitar pickups, microphone etc.) to achieve the best possible signal-to-noise ratio (SNR).

First adjust the **line/mic** switch on each channel according to your signal source: **mic** is suitable for microphones, **line** for pickups and other signal sources.

Turn the **gain** control clockwise until the red **clip** indicator flashes momentarily when playing with a strong attack. Now lower the **gain** control (and also the instrument's volume control) again slightly to get some headroom for an undistorted reproduction. The **clip** control LED should now only rarely flash. In case you find the level setting difficult because the input signal is too strong, press the **pad** switch as well. If the input signal is too weak, the **gain** control must be increased accordingly. With signal sources with a sufficient input signal strength the **gain** control should be adjusted between the '9:00 and 11:00 o'clock' position. Finally set the desired overall volume level with the **master** control.

• Equalization

The three-band equalizer with individual **bass**, **middle** and **treble** control of your **Alpha** has been designed in such a way that it both complies with the special requirements of acoustic instruments and also with the more general demands of other sources. The **colour** switch activates a midrange contour filter which is especially useful for picking techniques.

One more note: Adjusting the EQ controls can also affect the level setting. Whenever you see the **clip** indicator flashing frequently, you should slightly correct your **gain** setting (see 'Level adjustment').

• Effects

The **Alpha** has a built-in (internal) reverb effect processor. The **effect** control determines the intensity of the internal effect (left stop = no effect). Furthermore an additional effects unit (external effect) may be connected. For this purpose please use the send and return sockets located on the back of the amplifier (send goes to Input, **return** is connected to the output of the external effects device). The intensity is then adjusted at the external effects unit. The external effects loop works in *parallel* mode, i.e. the effect signal is blended with the original signal.

A standard double footswitch can be connected to the **footswitch** socket on the rear of the amp with a stereo cable. This switch can be used to turn the internal and external effects on and off.

We wish you hours of happy playing with your Alpha!

5. Technical Data

Inputs	
Input one	Combo socket, XLR + jack ¼" (6.35 mm) <hr/> line mode: High impedance, unbalanced input for instruments (pick-ups) and line-level sources Jack socket only Sensitivity: 15 mV (-36 dBV, note 4) Impedance: 1 Meg Equivalent input noise, A-weighted: 2.5 uV (-112 dBV) <hr/> mic mode: XLR (balanced), stereo jack (balanced), or mono jack (unbalanced) input Sensitivity: 2 mV (-54 dBV, note 4) Impedance (balanced mode): 1.2 k Impedance (unbalanced mode): 3.4 k Voice filter: -10 dB at 270 Hz (referred to 10 kHz) Equivalent input noise, A-weighted: 2.3 uV (-113 dBV) Phantom power: 24 V (XLR only) <hr/> Input two High impedance, unbalanced input for instruments (pick-ups) and line-level sources Mono jack socket, ¼" (6.35 mm) Sensitivity: 13 mV (-38 dBV) Pad switch (attenuator): -10 dB Impedance: 2.2 Meg Equivalent input noise, A-weighted: 1.5 uV (-116 dBV) Phantom power: Optional (note 4) <hr/> Return Return input for external parallel effect loop Mono jack, ¼" (6.35 mm) Sensitivity: 170 mV (-15 dBV) Impedance: > 5 k <hr/> Clip Indicator Headroom: min. 8dB below clipping
Outputs (note 3)	
Headphones	Headphones output. When plugged in, internal speaker is muted. Stereo jack, ¼" (6.35 mm, L and R are connected) Max. output power: 2 x 65 mW / 1000 ohms Input sensitivity for 2 x 50 mW / 1000 ohms: 18 mV (-35 dBV) at input 1, line mode Impedance: 470 ohms Note: Suitable for headphones with stereo jack plug only. Does not work with mono plugs.
Line out	Preamplifier output after master volume Mono jack, ¼" (6.35 mm) Output voltage: 1.2 V
DI-out	Unbalanced XLR output before master, after tone controls, without effects 1+3 = gnd 2 = signal output Output voltage: 560 mV
Send	Send output for parallel effect loop, before master, after tone controls Mono jack, ¼" (6.35 mm) Output voltage: 560 mV

Footswitch connector	
Footswitch	On/off switches for internal and external effects tip = internal, ring = external and sleeve = common (ground) Effect is OFF when the footswitch is ON.

Tone controls	
Colour (input 2 only)	-3 dB at 700 Hz +10 dB at 8 kHz
Bass	± 8 dB at 100 Hz, shelf type
Middle	± 6 dB at 800 Hz
Treble	± 8 dB at 10 kHz, shelf type
Effects	
Internal effect	Digital Reverb
External effect	Parallel effect loop (see send and return)
Power	
Power amp	40 W / 4 ohms, DMOS, monolithic I.C. Dynamic range, A-weighted: 92 dB (note 2).
Limiter threshold	35 W
Analog signal processing	Dedicated equalizer, subsonic filter, adaptive peak limiter
Speaker system	8" (200 mm) twin cone full-range speaker bass reflex enclosure
Mains power	Mains voltage (depending on model): 100, 120, 230, or 240 V AC, 50–60 Hz. Power consumption: max. 100 W
Mains fuse	5x20 mm Slow 1 A for 230 and 240 V models Slow 2 A for 100 and 120 V models
General	
Cabinet	12 mm (0.47") finnish birch plywood
Finish	Waterbased acrylic, black spatter finish
Dimensions	260 mm (10.24") high 265 mm (10.43") wide 235 mm (9.25") deep
Weight	6,2 kg (13.67 lbs)

Notes:

1. Input sensitivity

Input sensitivities refer to 35 watts into 4 ohms, full gain and master settings, neutral tone control settings, and 1 kHz sine-wave test signal.

2. Noise and dynamic range

Equivalent input noise voltage was obtained by measuring noise voltage at speaker output and dividing by the effective voltage gain of the amplifier. Full gain and master settings, neutral tone control settings, input shorted, measuring bandwidth 20 Hz – 20 kHz.

Dynamic range of power amplifier: Range between output signal at limiter threshold and A-weighted output noise with master volume in zero position.

3. Output levels

Output levels refer to 50 mV / 1 kHz sine-wave test signal at channel 1 input in line mode, full gain and master settings, and neutral tone control settings.

4. Options

1) Gain of input 1 (both line and mic) can be reduced by 3.5 dB by jumper setting
 2) +15 volts phantom power at ring of input 2 jack can be activated by solder bridge. Caution: Modified input is not compatible with mono jack plugs anymore! Mono plugs will short-circuit the power supply which may damage the amp!

Specifications and appearance subject to change without notice.

6. Block Diagram

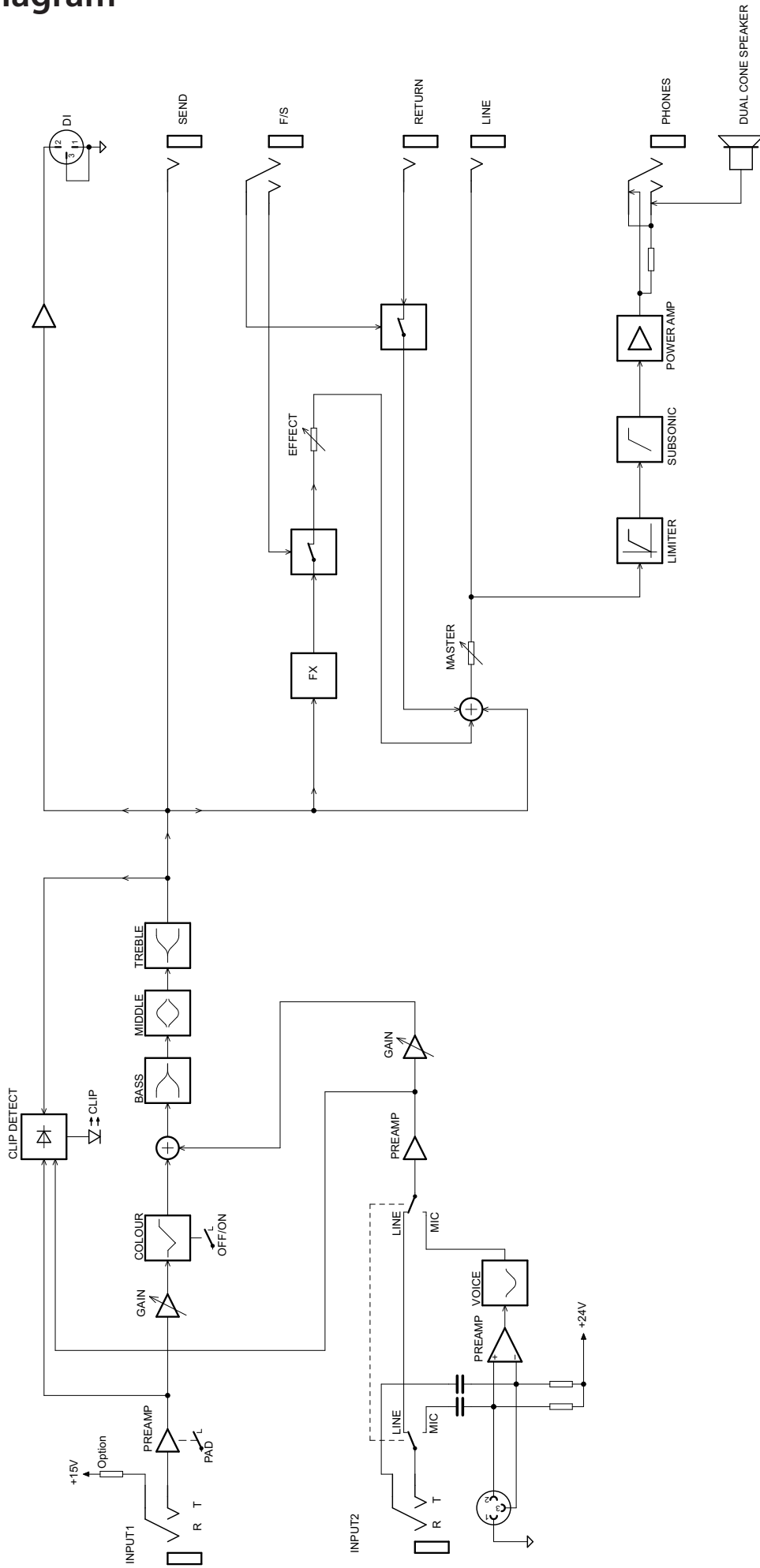

7. Manufacturer's Declaration

The disposal of electronic equipment in household waste is not permitted. AER GmbH waste electrical and electronic equipment is not to be taken to public collection points for disposal.

AER GmbH remains solely responsible for the disposal of AER GmbH waste electrical and electronic equipment labelled with a dustbin.

To dispose of AER GmbH waste electrical and electronic equipment that is labelled with a dustbin symbol, please contact us; we will ensure correct and cost-neutral disposal.

In the case of AER GmbH waste electrical and electronic equipment that is not labelled with a dustbin, the owner is responsible for correct disposal in accordance with the law.

However, we are also happy to help in this case and we can present you with the options of where to dispose of these electrical goods.

The telephone number of AER GmbH: +49 (0)2361 891789

Here, we will provide you with qualified information on the disposal of AER GmbH waste electrical and electronic equipment.

Declaration

The EU directive on the disposal of waste electrical and electronic equipment (WEEE, 2002/96/EC) has been changed to the electrical and electronic equipment act.

All AER electrical equipment affected by WEEE has been labelled with the symbol of a crossed out dustbin since 13.08.2005.

This symbol indicates that the disposal of the equipment is not permitted with household waste. It has been circulated in this form since 13.08.2005.

In the German registration department EAR, AER GmbH has been registered under WEEE registration number DE26301529.

European Union, Norway, Iceland and Lichtenstein

The disposal of electronic equipment in household waste is not permitted.

All AER electrical equipment affected by WEEE has been labelled with the symbol of a crossed out dustbin since 13.08.2005. This is also applicable for Norway, Iceland and Liechtenstein.

This symbol indicates that the disposal of the equipment is not permitted with household waste.

It has been circulated in this form since 13.08.2005.

The European directives of WEEE are anchored in different respective national laws in all European states. As such, we are unfortunately unable to provide you with one standard disposal solution.

The distributor or importer for the respective state is responsible for the observance of the laws of that state and must ensure the disposal of the waste electrical and electronic equipment in accordance with national regulations.

Other Countries

For correct disposal of the electrical goods, please ask the local dealer or the appropriate authority.

