

BH15H Handsome Devil Guitar Amplifier Head

User's Guide



TABLE OF CONTENTS

Introduction	3
BH15H Special Features.....	4
The Front Panel	5
The Rear Panel	6
Important Information About Tubes and Tube Products	8
System Block Diagram.....	11
Technical Specifications.....	12

IMPORTANT SAFETY INSTRUCTIONS

1. Read these instructions.
2. Keep these instructions.
3. Heed all warnings.
4. Follow all instructions.
5. Do not use this apparatus near water.
6. Clean only with a dry cloth.
7. Do not block any ventilation openings. Install in accordance with the manufacturer's instructions.
8. Do not install near any heat sources such as radiators, heat registers, stoves, or other apparatus (including amplifiers) that produce heat.
9. Do not defeat the safety purpose of the polarized or grounding-type plug. A polarized plug has two blades with one wider than the other. A grounding-type plug has two blades and a third grounding prong. The wide blade or the third prong are provided for your safety. If the provided plug does not fit into your outlet, consult an electrician for replacement of the obsolete outlet.
10. Protect the power cord from being walked on or pinched particularly at plugs, convenience receptacles, and the point where they exit from the apparatus.
11. Only use attachments/accessories specified by the manufacturer.
12. Use only with a cart, stand, tripod, bracket, or table specified by the manufacturer, or sold with the apparatus. When a cart is used, use caution when moving the cart/apparatus combination to avoid injury from tip-over.
13. Unplug this apparatus during lightning storms or when unused for long periods of time.



14. Refer all servicing to qualified service personnel. Servicing is required when the apparatus has been damaged in any way, such as power-supply cord or plug is damaged, liquid has been spilled or objects have fallen into the apparatus, the apparatus has been exposed to rain or moisture, does not operate normally, or has been dropped.
15. Do not overload wall outlets and extension cords as this can result in a risk of fire or electric shock.
16. This apparatus shall not be exposed to dripping or splashing, and no object filled with liquids, such as vases or beer glasses, shall be placed on the apparatus.
17. This apparatus has been designed with Class-I construction and must be connected to a mains socket outlet with a protective earthing connection (the third grounding prong).
18. This apparatus has been equipped with an all-pole mains switch. This switch is located on the front panel and should remain readily accessible to the user.

	CAUTION AVIS RISK OF ELECTRIC SHOCK. DO NOT OPEN RISQUE DE CHOC ELECTRIQUE. NE PAS OUVRIR	
<small>CAUTION: TO REDUCE THE RISK OF ELECTRIC SHOCK DO NOT REMOVE COVER (OR BACK) NO USER-SERVICEABLE PARTS INSIDE. REFER SERVICING TO QUALIFIED PERSONNEL ATTENTION: POUR EVITER LES RISQUES DE CHOC ELECTRIQUE, NE PAS ENLEVER LE COUVERCLE. AUCUN ENTRETIEN DE PIECES INTERIEURES PAR L'USAGER. CONFIER L'ENTRETIEN AU PERSONNEL QUALIFIE. AVIS: POUR EVITER LES RISQUES D'INCENDIE OU D'ELECTROCUTION, N'EXPOSEZ PAS CET ARTICLE A LA PLUIE OU A L'HUMIDITE.</small>		



The lightning flash with arrowhead symbol within an equilateral triangle is intended to alert the user to the presence of uninsulated "dangerous voltage" within the product's enclosure, that may be of sufficient magnitude to constitute a risk of electric shock to persons.

Le symbole éclair avec point de flèche à l'intérieur d'un triangle équilatéral est utilisé pour alerter l'utilisateur de la présence à l'intérieur du coffret de "voltage dangereux" non isolé d'ampleur suffisante pour constituer un risque d'électrocution.



The exclamation point within an equilateral triangle is intended to alert the user of the presence of important operating and maintenance (servicing) instructions in the literature accompanying the appliance.
Le point d'exclamation à l'intérieur d'un triangle équilatéral est employé pour alerter les utilisateurs de la présence d'instructions importantes pour le fonctionnement et l'entretien (service) dans le livret d'instruction accompagnant l'appareil.



Introduction

Congratulations! You have just purchased what we believe to be one of the most significant objects that you'll acquire in your lifetime—a tube amp. If that's not enough, you've gone and gotten yourself a Blackheart Engineering tube amp. So let's take a big picture view of this for a second: You're a guitar player who could have bought anything to bring your mind-bending chops to life, to unleash upon the masses the wrath of your otherworldly, mad riffin' skills. Did you settle? No, because you're more than just "whatever." You're like, "hear me roar!" so you go tube. Not "hybrid," not "solid state," but all tube—from when you scream "jump!" until your speaker wails "how high sir!"

We like the way you do your hair. You've got style. Speaking of which, take a look at the way this amp is built. 16 gauge steel, 1/2" radius corners in a void-free birch ply cabinet that looks like Michelangelo covered it for you personally. How about a double-sided PCB with 2 ounce copper traces, so your big fat sound has lots to hold on to traveling through a classic boutique circuit path designed by none other than Pyotr Belov himself. The guy's got a soldering iron in his hands most hours of the night so if he says "make the thing like a tank," everyone agrees real quickly. Who knows, you might be in some sort of edge band; knock the thing around a bit. That's a Blackheart thing. We make rock-solid, no compromise music gear that sounds like choruses of angels singing big, beefy power chords. We work with glass, metal and wood just like the powers that be intended when they created rock and roll. We take every amp personally and we do it assuming you worked hard to get it and we're not letting you down. That fancy tattoo logo was inspired by one of our test animals.* He said a great amp leaves a permanent mark on your tone, and shapes how you play, write, perform, etc. So, when you laid down coin for a Blackheart, you kind of got hitched.

And it didn't set you back much, especially when you consider what you got. Every Blackheart design starts as a hand-built masterpiece with no thoughts about cutting cost or going for it on the cheap. Pyotr picks every component one by one and tweaks until his ears hear the tone. Once he's given birth to the prototype (ouch!), he personally works with offshore manufacturing to translate that exact tone into the most affordable piece of gear that won't let you down. Literally, he works in the factory, training other people how to build boutique-quality amps and sits on the QC line before anything gets into a box. Blackheart isn't the cheapest—plenty of other amps are cheap and you can have your pick. We prefer to be ultra-high quality and performance for a price that anyone can afford.

So thanks for laying down your hard earned cash for a Blackheart Engineering product. We're not going to disappoint you. You've got, in your hands, one of the best sounding, best quality, old school inspired amps that's ever been made.

Vous avez notre coeur,

Blackheart Engineering

* We don't test on little furry helpless animals of course. We call our artists animals because, well, we've eaten with them. They give their time and opinions to us on a regular basis and have a lot to do with how good your Blackheart is.

CONSIGNES DE SECURITE IMPORTANTES

- LIRE, SUIVRE TOUTES LES INSTRUCTIONS ET LES PRECAUTIONS D'UTILISATION
- NE PAS UTILISER PROCHE D'UNE SOURCE DE CHALEUR ET NE PAS BLOQUER OU OBSTRUER LE SYSTEME DE VENTILATION SUR CET APPAREIL. POUR UNE UTILISATION CONFORME, CET APPAREIL NECESSITE ENVIRON 7CM D'ESPACE BIEN VENTILE AUTOUR DE SON SYSTEME DE REFROIDISSEMENT, AINSI QU'UN COURANT D'AIR FRAIS CONSTANT
- NE PAS UTILISER CET APPAREIL PROCHE D'UNE SOURCE LIQUIDE
- NETTOYER SEULEMENT A L'AIDE D'UN CHIFFON DOUX ET SEC ET NE PAS UTILISER DE PRODUITS MENAGERS
- CONNECTER UNIQUEMENT LE CABLE D'ALIMENTATION FOURNI SUR UNE PRISE AVEC MISE A LA TERRE, ET COMPATIBLE AVEC LA TENSION, L'INTENSITE ET LA FREQUENCE REQUISES INDIQUEES SUR LA FACE ARRIERE DE L'APPAREIL
- S'ASSURER DE NE PAS MARCHER, PLIER OU TIRER SUR LE CABLE D'ALIMENTATION
- DEBRANCHER L'APPAREIL LORS D'UNE TEMPETE OU LORS D'UNE TRES LONGUE PERIODE DE NON UTILISATION
- UTILISER UNIQUEMENT DES ACCESSOIRES SPECIFIES PAR LE FABRICANT POUR UNE UTILISATION EN TOUTE SECURITE ET POUR EVITER DES BLESSURES
- **ATTENTION:** AFIN DE PREVENIR TOUT RISQUE DE CHOC ELECTRIQUES OU DE DEBUT D'INCENDIE, NE PAS EXPOSER CET APPAREIL A LA PLUIE ET A L'HUMIDITE
- TOUT ENTRETIEN DOIT ETRE FAIT PAR UN TECHNICIEN QUALIFIE
- NOS AMPLIFICATEURS PEUVENT PRODUIRE DE TRES HAUTES PRESSIONS ACOUSTIQUES QUI PEUVENT CAUSER DES DOMMAGES AUDITIFS PERMANENTS OU DEFINITIFS. L'UTILISER AVEC UNE GRANDE PRECAUTION EST CONSEILLE ET DES PROTECTIONS AUDITIVES SONT RECOMMANDEES POUR UNE UTILISATION A FORT VOLUME.
- **ATTENTION:** CET APPAREIL REQUIERT UNE PRISE MURALE AVEC MISE A LA TERRE, AUX NORMES ACTUELLES ET COMPATIBLE AVEC LES SPECIFICATIONS ELECTRIQUES SE TROUVANT EN FACE ARRIERE DE L'APPAREIL. LA PRISE ELECTRIQUE DOIT RESTER ACCESSIBLE POUR DEBRANCHER L'APPAREIL EN CAS DE DEFAUT PENDANT L'UTILISATION
- CET APPAREIL DOIT ETRE DEBRANCHE SI IL N'EST PAS UTILISE

Elimination correcte du produit : Ce symbole indique que ce produit ne doit pas être éliminé avec les ordures ménagères, comme le prévoit la directive WEEE (2002/96/EC) et votre loi nationale.

Ce produit doit être remis à un site de recyclage des déchets électriques et des équipements électroniques (EEE).

Un mauvais recyclage de ce type de déchet peut avoir de possibles impacts négatifs sur l'environnement et la santé humaine dus aux émanations de substances.

Dans un même temps, votre coopération à un recyclage correct de ce produit contribuera à la bonne utilisation des ressources naturelles.

Pour connaître l'endroit où il est possible de recycler ces équipements, merci de contacter votre mairie, les services de recyclages ou le service des déchets ménagers.



BH15H Special Features:

- Push-Pull Class A circuit
- All tube signal path
- Two 12AX7/ECC83 dual-triode preamp tubes and two EL84/6BQ5 pentode output tubes
- Pentode (15W RMS) Triode (7W RMS) switch
- DC filament power supply for preamp tubes
- 3-band EQ, Level (Master Volume) Control and Presence Control
- 16-gauge (1.5 mm) thick, folded and spot welded steel chassis
- Double-sided custom color PCB with 2 oz. copper
- 15-ply, 18 mm thick, void-free birch plywood construction
- 16 ohm, two 8 ohm, and two 4 ohm speaker outputs
- Kicks sound in the faces of all those who have wronged you





The Front Panel

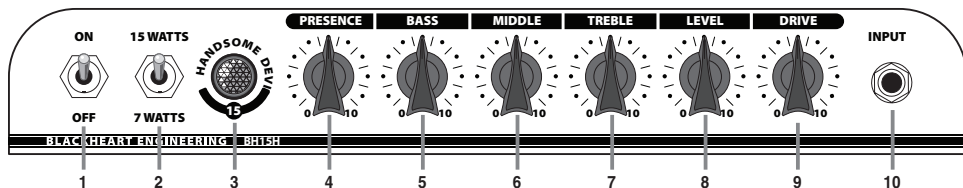

- 1. ON/OFF SWITCH:** Use this switch to turn the amplifier on and off.
- 2. 15 WATTS/7 WATTS:** This is the Pentode/Triode switch. It allows you to operate the amplifier in two distinct modes of operation and output power rating. The Pentode is the aggressive setting that gives you full output power of 15 watts RMS. The Triode is a gentler setting with more head room that reduces the output power to 7 watts RMS.
- 3. INDICATOR LAMP:** This illuminates when the amplifier is turned on (power, that is).
- 4. PRESENCE:** Use this to boost the high frequency response and overall punch of the output section. The adjustment range is +28dB at 20 kHz.
- 5. BASS:** Use this to adjust the output level of the low frequencies. The adjustment range is +10 dB at 100 Hz.
- 6. MIDDLE:** Use this to adjust the output level of the mid frequencies. The adjustment range is +6 dB at 1 kHz.
- 7. TREBLE:** Use this to adjust the output level of the high frequencies. The adjustment range is +14 dB at 10 kHz.
- 8. LEVEL:** Use this to adjust output volume of the amplifier.
- 9. DRIVE:** Use this to adjust the amp gain of the amplifier
- 10. INPUT:** Use this jack to connect your guitar to the amplifier using a high-quality shielded instrument cable.



The Rear Panel

HANDSOME DEVIL 15 - PUSH PULL/CLASS A AMPLIFIER
LOUDSPEAKER OUTPUTS
POWER OUTPUT 15 WATTS RMS
CONNECT SPEAKERS BEFORE USE

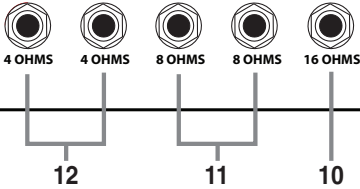

The rear panel has connections for the AC power cord and external speaker cabinets.

WARNING! Never turn on or use the amplifier without a load or speaker connected to the amplifier.

9. AC Power Input with Mains Fuse:

The amplifier is equipped with a detachable power cord that plugs into this IEC Mains socket. The AC power cord should only be plugged into a grounded power outlet that meets all applicable electrical codes and is compatible with the voltage, power, and frequency requirements stated on the rear panel of the amplifier. Do not attempt to defeat the safety ground connection. The AC Mains fuse is located in the IEC Mains socket and is used to protect the amplifier from electrical faults. If the fuse needs to be replaced, please refer to the correct fuse specifications located on the back panel of the amplifier. Always unplug the power cord when changing or inspecting the fuse. Never bypass the fuse or replace it with a wrong type or value.

10. 16 OHMS: This output can power an external speaker cabinet rated at 16 ohms (see top-left figure on next page).

11. 8 OHMS: The two 8 ohms speaker output jacks are wired in parallel. See the connection examples on the next page.

12. 4 OHMS: The two 4 ohms speaker output jacks are wired in parallel. See the connection examples on the next page.

Connecting speaker cabinets

The hookup diagrams on the next page show some different cabinets, their impedance, where to plug them in, and the total load impedance placed on the amplifier.

ALWAYS use good quality (non-shielded) speaker cable to connect speaker cabinets. Never use (shielded) instrument cable.

ALWAYS match the amplifier's speaker output impedance to the impedance of the speaker that is being used.

- Use only one type of impedance output at a time.
- If more than one speaker is connected at the same time, make sure they all have the same impedance rating.
- Never use two or more cabinets with different impedance ratings. This will create an unbalanced load.
- When using multiple speaker cabinets (with the same impedance rating), match the total load impedance of the speaker cabinets to the speaker output of the amplifier.

For equal-impedance speakers connected in parallel, the first law of rock and roll states:

$$\text{SPEAKER CABINET IMPEDANCE divided by NUMBER OF CABINETS} = \text{TOTAL LOAD}$$



Typical connections to speaker cabinets

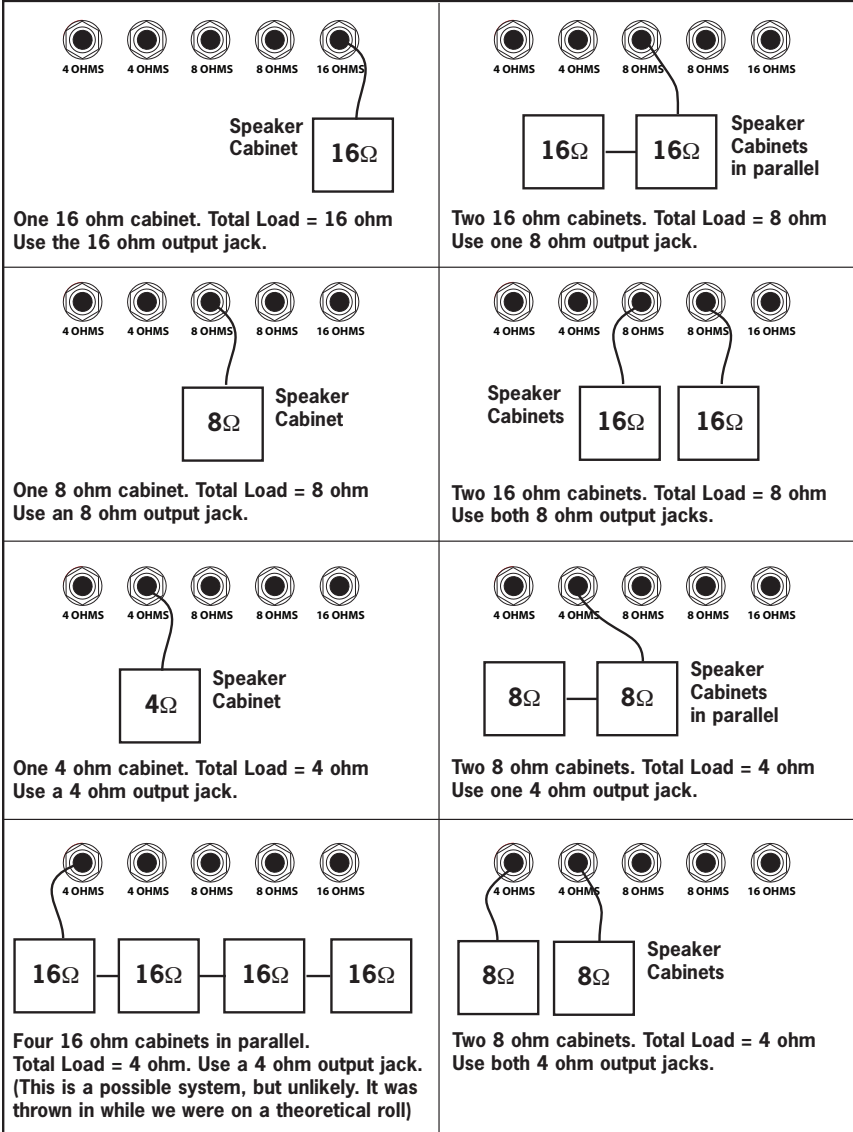



Important Information about Tubes and Tube Products:

The Nature Of Tubes — Why (And When) To Replace Them:

Tubes are made up of a number of fragile mechanical components that are vacuum-sealed in a glass envelope or bubble. The tube's longevity is based on a number of factors which include how hard and often the amplifier is played, vibration from the speakers, road travel, repeated set up and tear down, etc.

Any time you notice a change in your amplifier's performance, check the tubes first.

If it's been a while since the tubes were replaced and the sound from your amplifier lacks punch, fades in and out, loses highs or lows or produces unusual sounds, the power tubes probably need to be replaced. If your amplifier squeals, makes noise, loses gain, starts to hum, lacks "sensitivity", or feels as if it is working against you, the preamplifier tubes may need to be replaced.

The power tubes are subjected to considerably more stress than the preamplifier tubes. Consequently, they almost always fail/degrade first. If deteriorating power tubes aren't replaced they will ultimately fail. Depending on the failure mode, they may even cause severe damage to the audio output transformer and/or other components in the amplifier. Replacing the tubes before they fail completely has the potential to save you time, money and unwanted trouble. Since power tubes work together in an amplifier, it is crucial that they (if there is more than one) be replaced by a matched set. If you're on the road a lot, we recommend that you carry a spare matched set of replacement power tubes and their associated driver tubes.

After turning off the power and disconnecting the amplifier from the power source, carefully check the tubes (in bright light) for cracks or white spots inside the glass or any other apparent damage. Then, with the power on, view the tubes in a dark room. Look for preamplifier tubes that do not glow at all or power tubes that glow excessively red.

Whenever you replace the power tube(s):

- Always have the amplifier's bias voltage checked by a qualified service center. Improper bias voltage will cause degradation in performance and possibly damage the tubes and/or the amplifier. (See "The Importance of Proper Biasing", below for more information).
- We highly recommend that you replace the driver tube(s) as well. The driver tube determines the shape and amplitude of the signal applied to the power tube(s) and has to work almost as hard as the power tube(s).

You can check your preamplifier tubes for microphonics by turning the amplifier on, turning up the gain and tapping lightly on each tube with the end of a pencil or a chop stick (my favorite). You will be able to hear the tapping through your speakers, which is normal. It is not normal for a tube to ring like a bell after it's tapped. If it does ring then it's microphonic and should be replaced. Remember to use only high quality, low microphonic tubes in the preamplifier section.

Even though power tubes are rarely microphonic, you should check them anyway. The power tubes can be checked for microphonics just like pre-amp tubes.

In the case of very high gain amps, you may be able to reduce the amount of noise generated by simply swapping the preamp tubes around.



Important Information About Tubes and Tube Products (continued):

The Importance Of Proper Biasing:

For the best performance and longest tube life, proper biasing is imperative. Bias is the negative voltage which is applied to the power tube's control grid to set the level of idle current. We cannot over emphasize the difference in warmth of tone and dynamic response that come with proper biasing. If the bias is set too high (over biased), the sound from the amp will be distorted at all levels. If the bias is set too low, (under biased) the power tubes will run hot (the plates inside the tubes may glow red due to excessive heat) and the sound from the amplifier will lack power and punch. The excessive heat greatly reduces tube life – from a few days to as little as a few hours in extreme cases. Setting the bias on your amp is like setting the idle on your car. If it's too high or hot it's running away with you and if it's too low or cold it will choke when you step on it.

The bias is adjusted at the factory in accordance with the type of power tube(s) installed in your amplifier. It is important to point out that tubes of the same type and specification typically exhibit different performance characteristics. Consequently, whenever power tubes are replaced, the bias voltage must be checked (unless the amplifier is equipped with "self-biasing" circuitry) and readjusted to accommodate the operating parameters of the replacement tubes.

Depending on the model and amplifier type, there may be hum balance controls, trim pots, or bias adjustment controls on its rear panel. However, the bias adjustment should be performed only by qualified service personnel with the proper, calibrated test equipment.



Important Information About Tubes and Tube Products (continued):

Survival Tips For Tube Amplifiers:

To prolong tube life, observe these tips and recommendations:

- Match the impedance of your speaker cabinet(s) to your amplifier. Improper impedance matching will contribute to early tube degradation and may cause premature tube failure.
- Make sure the speaker(s) are properly connected prior to turning on the amplifier.
- After playing the amplifier, allow sufficient time for it to properly cool down prior to moving it. A properly cooled amplifier prolongs tube life due to the internal components being less susceptible to the damage caused by vibration.
- Allow the amplifier to warm up to room temperature before turning it on. The heat generated by the tube elements can crack a cold glass housing.
- Replace the output tube(s) before the performance degrades or the tubes fail completely. Replace the tube(s) on a regular basis (at least once per year or as often as every 4 to 6 months if you play long and hard every day).
- Always have the bias checked after replacing the output tubes (unless the amplifier is equipped with “self-biasing circuitry”). This should be done **ONLY** at a qualified service center. Improper biasing could result in the tubes running too hot, which greatly reduces the life of the tubes – or too cold, which results in distorted sound regardless of level settings. Do not play the amplifier if it exhibits these symptoms – get the bias checked/adjusted immediately to prevent tube failure and/or other damage.
- If the locating notch on the base of a power tube breaks off, replace the tube. This significantly reduces the risk of damaging your amplifier by incorrectly inserting the tube.
- Protect the amplifier from dust and moisture. If liquid gets into the amplifier proper, or if the amplifier is dropped or otherwise mechanically abused, have it checked out at an authorized service center before using it.
- Proper maintenance and cleaning in combination with routine checkups by your authorized service center will insure the best performance and longest life from your amplifier.

CAUTION: Tube replacement should be performed only by qualified service personnel who are familiar with the dangers of hazardous voltages that are typically present in tube circuitry.



System Block Diagram

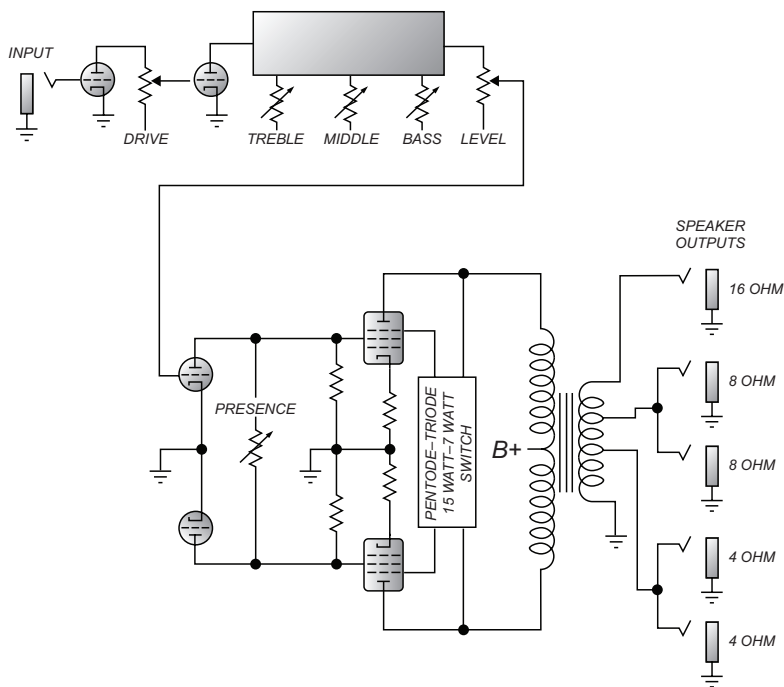

NOTE: This equipment has been tested and found to comply with the limits for a Class B digital device, pursuant to part 15 of the FCC Rules. These limits are designed to provide reasonable protection against harmful interference in a residential installation. This equipment generates, uses, and can radiate radio frequency energy and, if not installed and used in accordance with the instructions, may cause harmful interference to radio communications. However, there is no guarantee that interference will not occur in a particular installation. If this equipment does cause harmful interference to radio or television reception, which can be determined by turning the equipment off and on, the user is encouraged to try to correct the interference by one or more of the following measures:

- Reorient or relocate the receiving antenna.
- Increase the separation between the equipment and the receiver.
- Connect the equipment into an outlet on a circuit different from that to which the receiver is connected.
- Consult the dealer or an experienced radio/TV technician for help.

CAUTION: Changes or modifications to this device not expressly approved by LOUD Technologies Inc. could void the user's authority to operate the equipment under FCC rules.

This apparatus does not exceed the Class A/Class B (whichever is applicable) limits for radio noise emissions from digital apparatus as set out in the radio interference regulations of the Canadian Department of Communications.

ATTENTION — Le présent appareil numérique n'émet pas de bruits radioélectriques dépassant les limites applicables aux appareils numériques de class A/de class B (selon le cas) prescrites dans le règlement sur le brouillage radioélectrique édicté par les ministere des communications du Canada.

Exposure to extremely high noise levels may cause permanent hearing loss. Individuals vary considerably in susceptibility to noise-induced hearing loss, but nearly everyone will lose some hearing if exposed to sufficiently intense noise for a period of time. The U.S. Government's Occupational Safety and Health Administration (OSHA) has specified the permissible noise level exposures shown in the following chart.

According to OSHA, any exposure in excess of these permissible limits could result in some hearing loss. To ensure against potentially dangerous exposure to high sound pressure levels, it is recommended that all persons exposed to equipment capable of producing high sound pressure levels use hearing protectors while the equipment is in operation. Ear plugs or protectors in the ear canals or over the ears must be worn when operating the equipment in order to prevent permanent hearing loss if exposure is in excess of the limits set forth here:

Duration, per day in hours	Sound Level dBA, Slow Response	Typical Example
8	90	Duo in small club
6	92	
4	95	Subway Train
3	97	
2	100	Very loud classical music
1.5	102	
1	105	Pyotr screaming at Zane and Troy about deadlines
0.5	110	
0.25 or less	115	Loudest parts at a rock concert



BH15H TECHNICAL SPECIFICATIONS

Output Power Rating	Pentode: 15 W rms @ 12.3% THD, 16 ohm load Triode: 7 W rms @ 9% THD, 16 ohm load
Signal-to-Noise Ratio	63 dB, Typical
Input Impedance	1 Meg Ohm
EQ	Treble: 14 dB range @ 10 kHz Middle: 6 dB range @ 1 kHz Bass: 10 dB range @ 100 Hz
Presence:	10.2 dB range @ 100 Hz 28 dB range @ 20 kHz
Preamp Tubes	2 x 12AX7/ECC83
Power Tubes	2 x EL84/6BQ5
Rectifier	Solid State
Speaker Outputs	1 x 16 ohms 2 x 8 ohms (8 ohms total load impedance) 2 x 4 ohms (4 ohms total load impedance)
Power Requirements	110/120 VAC, 50/60 Hz, 90 W 220/240 VAC, 50/60 Hz, 90 W
AC Mains Fuse	100/120 VAC: T2.AL 250V Fuse 220/240 VAC: T1.AL 250V Fuse
Size (H x W x D)	9.6 in/243 mm (including feet) x 18.0 in/460 mm x 9.0 in/228 mm
Weight	28.6 lb/13 kg

The Blackheart BH15H Handsome Devil is covered with a durable fabric-backed vinyl material. Wipe it clean with a lint-free cloth. Never spray cleaning agents onto the cabinet. Avoid abrasive cleansers which would damage the finish.

Blackheart continually develops new products, as well as improves existing ones. For this reason, the specifications and information in this manual are subject to change without notice.

"Blackheart" is a registered trademark of LOUD Technologies Inc. All other brand names mentioned are trademarks or registered trademarks of their respective holders and are hereby acknowledged.

Service Information

If you are having a problem with your Blackheart BH15H Handsome Devil, you can go to our website (www.blackhearteng.com) and click on "Heart Surgery" for service information, or call 1-800-898-3211 Monday-Friday, during normal business hours, Pacific Time, to explain the problem. If you are outside of the U.S., contact your local distributor for technical support and service.



Correct disposal of this product: This symbol indicates that this product should not be disposed of with your household waste, according to the WEEE directive (2002/96/EC) and your national law. This product should be handed over to an authorized collection site for recycling waste electrical and electronic equipment (EEE). Improper handling of this type of waste could have a possible negative impact on the environment and human health due to potentially hazardous substances that are generally associated with EEE. At the same time, your cooperation in the correct disposal of this product will contribute to the effective usage of natural resources. For more information about where you can drop off your waste equipment for recycling, please contact your local city office, waste authority, or your household waste disposal service.

BLACKHEART ENGINEERING

AMPLIFIER SERIES

www.blackhearteng.com

@2009 LOUD Technologies Inc.

16220 Wood-Red Road NE • Woodinville, WA 98072

Part No. SW0754 Rev. C 04/09